

DEVELOPMENT SUMMARY

ZONING	EXISTING ZONING	R-20, O&I, NRC
	PROPOSED ZONING	RM-8
AREA	SITE AREA	8.59 ACRES
DENSITY	NUMBER OF UNITS	50 UNITS
	PROPOSED DENSITY	5.8 UNITS/ACRE
SETBACKS (PERIMETER)	FRONT	40 FEET
	SIDE	15 FEET
	SIDE MAJOR	25 FEET
	REAR	30 FEET
SETBACKS (INTERIOR)	FRONT	15 FEET
	SIDE	0 FEET
	SIDE MAJOR	5 FEET
	REAR	20 FEET
	MINIMUM HOUSE SIZE	1,400 SF
	MAXIMUM BUILDING HEIGHT	40 FEET
	MAXIMUM IMPERVIOUS AREA	45%
	PROPOSED IMPERVIOUS AREA	3.79 ACRES (41%)

24 HOUR CONTACT:
JEFF SMITH
404.328.6280

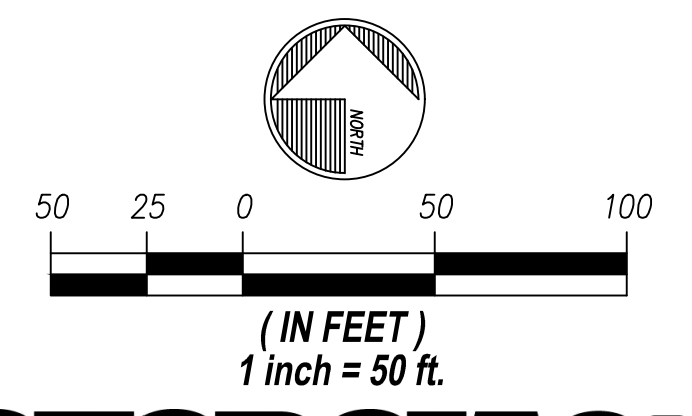

Know what's below. Call before you dig.

THE UTILITIES SHOWN HEREON ARE FOR THE CONTRACTORS CONVENIENCE ONLY. THERE MAY BE OTHER UTILITIES NOT SHOWN ON THESE PLANS. THE ENGINEER ASSUMES NO RESPONSIBILITY FOR THE LOCATIONS SHOWN AND IT SHALL BE THE CONTRACTOR'S RESPONSIBILITY TO VERIFY ALL UTILITIES WITHIN THE LIMITS OF THE WORK. ALL DAMAGE MADE TO EXISTING UTILITIES BY THE CONTRACTOR SHALL BE THE SOLE RESPONSIBILITY OF THE CONTRACTOR.