

DEVELOPMENT SUMMARY

ZONING	EXISTING ZONING	R-20, O&L, NRC
	PROPOSED ZONING	RA-6
AREA	SITE AREA	8.59 ACRES
DENSITY	NUMBER OF UNITS	47 UNITS
	PROPOSED DENSITY	5.47 UNITS/ACRE
SETBACKS (PERIMETER)	FRONT	40 FEET
	SIDE	20 FEET
	SIDE MAJOR	25 FEET
	REAR	40 FEET
SETBACKS (INTERIOR)	FRONT	*15 FEET
	SIDE	5 FEET
	SIDE MAJOR	*5 FEET
	REAR	40 FEET
	MAXIMUM BUILDING HEIGHT	35 FEET
	MAXIMUM IMPERVIOUS AREA	45%
	PROPOSED IMPERVIOUS AREA	3.1 ACRES (36%)

*VARIANCE REQUIRED

24 HOUR CONTACT:
MATT COUTU
404.969.9372

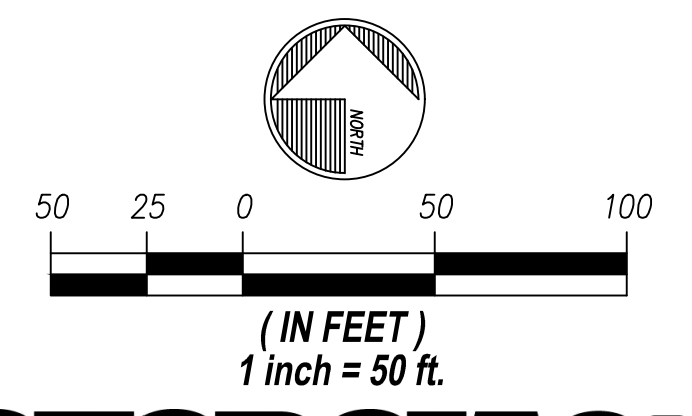

Know what's below.
Call before you dig.

THE UTILITIES SHOWN HEREON ARE FOR THE CONTRACTORS CONVENIENCE ONLY. THERE MAY BE OTHER UTILITIES NOT SHOWN ON THESE PLANS. THE ENGINEER ASSUMES NO RESPONSIBILITY FOR THE LOCATIONS SHOWN AND IT SHALL BE THE CONTRACTOR'S RESPONSIBILITY TO VERIFY ALL UTILITIES WITHIN THE LIMITS OF THE WORK. ALL DAMAGE MADE TO EXISTING UTILITIES BY THE CONTRACTOR SHALL BE THE SOLE RESPONSIBILITY OF THE CONTRACTOR.